

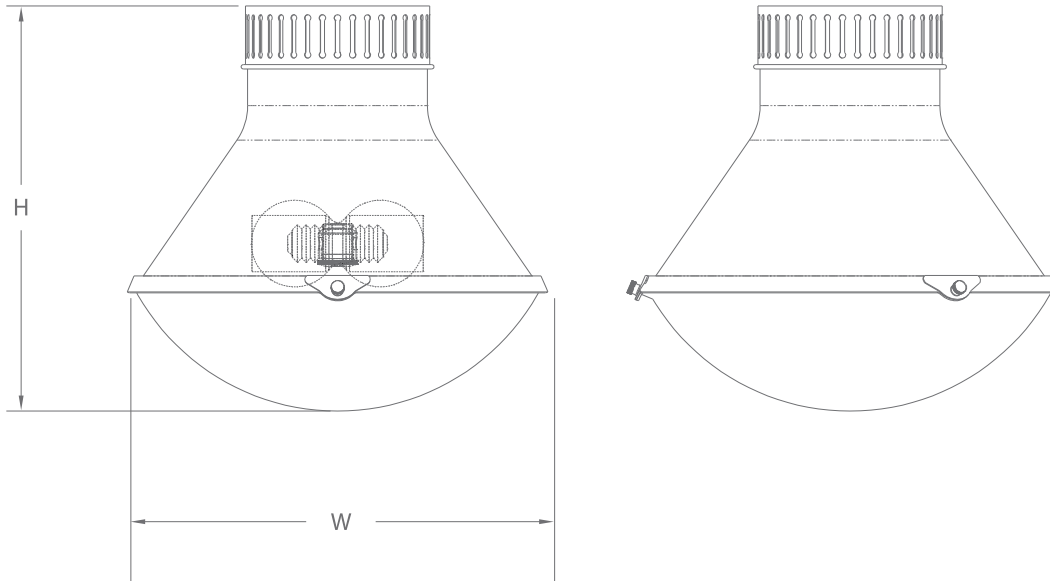

LUNDY



LUNDY

MARTIN BRUDNIZKI / MB-1460

		W	H	D	LAMP	CANOPY	X	Y	Z	ETL	WEIGHT
HANG LARGE	MB-1460HL	18	17.5		2-60W-S	8				DAMP	18 lbs
HANG REGULAR	MB-1460HR	12	12		2-60W-S	5.5				DAMP	9 lbs

AVAILABLE FINISHES

STANDARD	AB, BL, BP, BZ, HB, WH
PREMIUM I	AG, AS, DB, DT, GT, HN, PT, PW, SB, SG, VN, ZC
PREMIUM II	HR, PB, PBU, PN

AVAILABLE FOR ACCENTS

STANDARD	AB, BL, BP, BZ, HB, WH
PREMIUM	AG, AS, DB, DT, GT, HR, HN, PT, PW, PB, PBU, PN, SB, SG, VN, ZC

AVAILABLE GLASS

STANDARD	OP
PREMIUM	N/A

DETAILS



NOTES

Designed by Martin Brudnizki.  
 Photographed in RAL powder coat 5009 with polished nickel accents.  
 Ships with non-dimmable 12V transformer.  
 Standard with opal glass diffuser.  
 Ships with complimentary bulb(s).  
 © Copyright 2003-2014 The Urban Electric Co. All rights reserved.